



A. REMOVE ASSEMBLIES FROM CARTON

1. Remove handle assy & remove packing around it
2. Lift out main buffer assembly
3. Lift out battery carriage assembly

B. TO ASSEMBLE HANDLE TO MACHINE

1. Remove screw "A" at end of axle & slide one wheel off
2. Loosen screw "D" so clamp slides freely on handle
3. At "B" & "C" assemble handle loosely as shown with screw & nuts supplied on handles

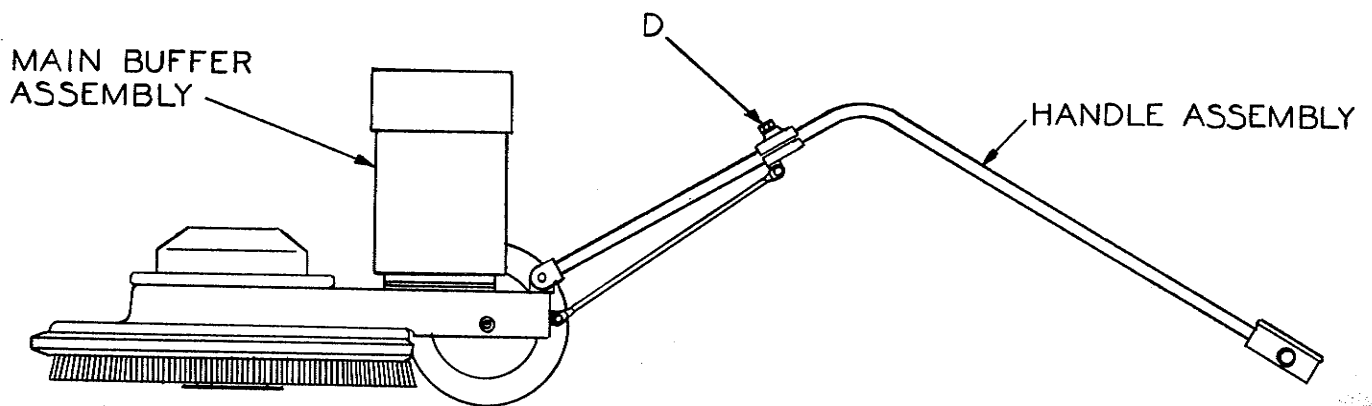

4. Reassemble wheel onto shaft & tighten screw "A" firmly
5. Raise handle to desired operating height & tighten screw "D" to lock handle in place. Then tighten screws at "B" and "C"

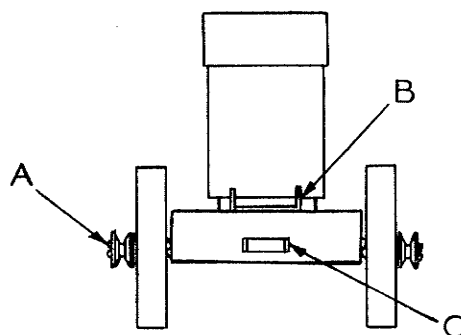

C. HOOK UP BATTERIES

1. Open battery case & remove packing around wires
2. Recommended battery - Gould PB105 or equal
3. Fill batteries with approved electrolyte of 1.265 specific gravity.

IMPORTANT: FOLLOW INSTRUCTIONS SUPPLIED WITH BATTERIES & ELECTROLYTE

4. Place batteries into battery case as shown on page 4 of this booklet. Make sure positive & negative poles are connected as shown. (Wiring diagram is also stamped on switch bracket).

D. CONNECT BATTERY CARRIAGE TO MACHINE

1. From behind machine, roll battery carriage in place, line up tongues on carriage with large washers on axle outside of wheels
2. Place foot against back of carriage lift & pull back on handle to lock machine & carriage together.

IMPORTANT: MAKE SURE SWITCH ON BATTERY CASE IS IN THE OFF POSITION (PULL UP)

3. Snap plug from carriage into plug from motor

E. FOLLOW OPERATING INSTRUCTIONS SUPPLIED IN LITERATURE PACK FOR CHARGING, BATTERY CARE & SAFETY PRECAUTIONS

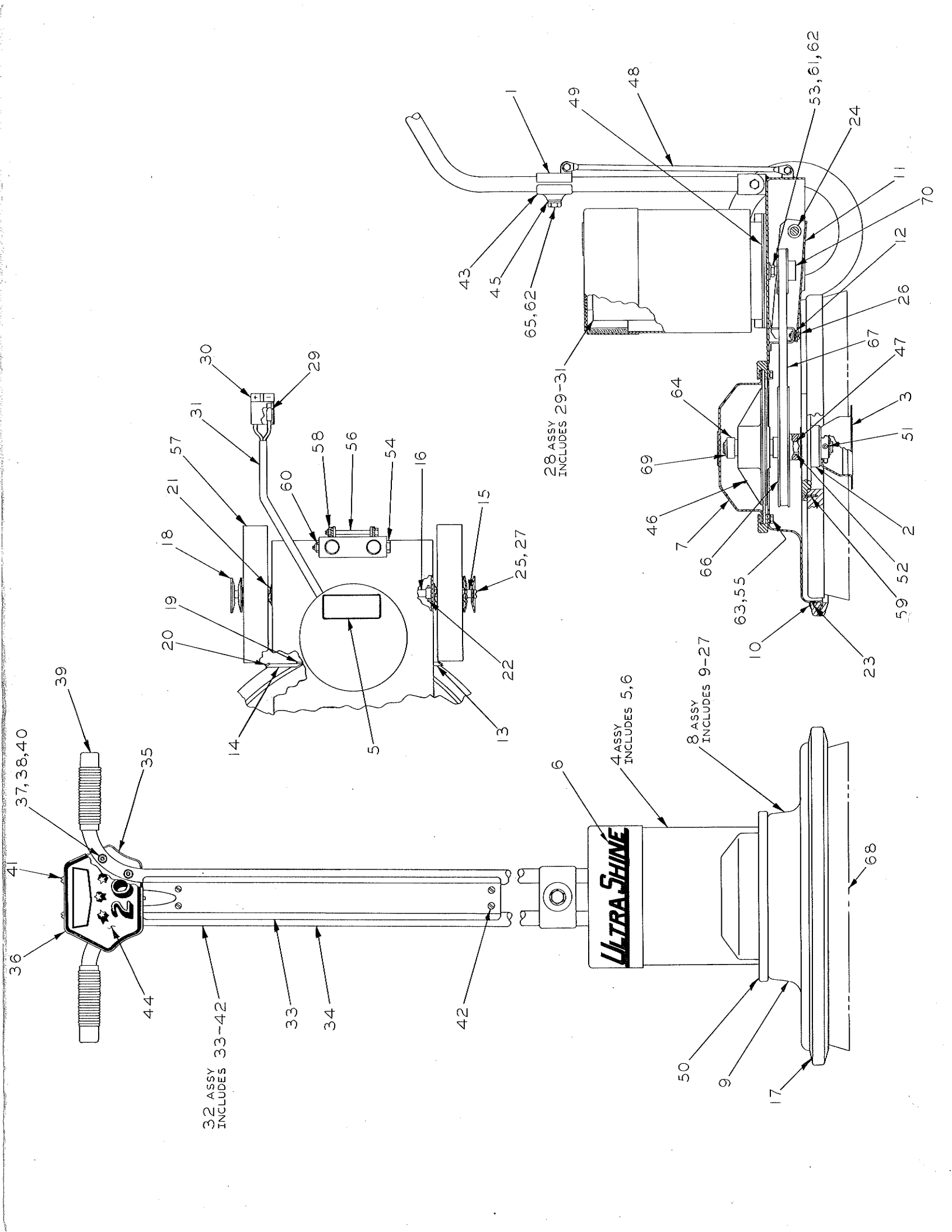

**PARTS BREAKDOWN
MODEL 20DC-HB E23561**



Assy. No.	Part No.	Per Assy	Description	Assy No.	Part No.	Per Assy	Description
1	A4054	1	Assy - Clamp Bottom & Insert	35	A23532	1	Assy - Switch Box & Weld Pin
2	B19970	1	Assy - Drive Hub & Pins	36	B14410	1	Switch Box Cover
3	B19976	1	Assy - Cup & Handle	37	K10652	4	Nut
4	C23516	1	Assy - Shroud & Decals (Includes 5, 6)	38	K2964-10	4	Shakeproof Lockwasher
5	A20219	1	Decal, Caution	39	K4879	2	Handle Grips
6	B21975	1	Decal, Ultra Shine	40	K5025-22	4	Round Head Machine Screws
7	B19962	1	Assy - Hood & Weld Nuts	41	K5113-4	2	Thread Cutting Screw
8	C23575	1	Assy - Base, Bumper, Axle, Belt Guard (Includes 9-27)	42	K6010-5	4	Pan Head Machine Screw
9	D19958	1	Assy - Base	43	B4030-5	1	Clamp, Top
10	C4113	1	Retainer, Bumper	44	B14400	1	Emblem, Cover
11	C19965	1	Guard, Belt	45	A18631	1	Washer
12	A19968	2	Washer, Rubber	46	C19960	1	Mount, Bearing
13	B22202-1	1	Bracket, Bumper	47	B20022	1	Shaft
14	B22202-2	1	Bracket, Bumper	48	B20023	2	Brace, Adjustment
15	A23299	2	Spacer	49	B20032	2	Spacer, Motor
16	A23501	1	Axle	50	B5116	1	Bumper, Motor
17	B21017	1	Bumper	51	K9559-4	2	Screw, Set
18	A23565	4	Washer	52	K9566-40	1	Key
19	K3701-6	2	Screw, Sheet Metal	53	K2949-8	3	Hex. Hd. Cap Screw
20	K3701-12	2	Screw, Sheet Metal	54	K2949-36	1	Hex. Hd. Cap Screw
21	K4252	4	Washer, Wave	55	K2998-5	4	Hex. Hd. Cap Screw
22	K5115	2	Pin, Roll	56	K2998-24	2	Hex. Hd. Cap Screw
23	K12161-4	11	Screw, Flat Hd.	57	K3143	2	Wheel
24	K15478	2	Grommet	58	K4948	2	Flex-Loc Nut
25	K15752-14	2	Lockwasher	59	K5196-7	6	Wood Screw, Flat Hd.
26	K15860-8	1	Screw, Pan Hd.	60	K5237	1	Flex-Loc Nut
27	K15860-16	2	Screw, Pan Hd.	61	K14880-6	3	Flat Washer
28	C23576	1	Assy - Motbr & Divider (Includes 29, 30, 31)	62	K14881-6	4	Lockwasher
29	K18383	2	Lug	63	K15752-14	4	Lockwasher
30	K18384	1	Housing, Plug	64	K15972	2	Bearing
31	K23813-14	1	Tubing, Insulating	65	K16566-16	1	Screw, Hex, Hd, Cap
32	D23577	1	Assy - Switch Box & Handle (Includes 33-42)	66	K20027	1	Pulley
33	C21312	1	Assy - Cover, Handle	67	K20028	1	Belt
34	D23523	1	Assy - Handle & Braces	68	K20352	1	18" Drive Pad Brush
				69	K22440	2	E-Ring
				70	K23508	1	Pulley, Motor

**PARTS BREAKDOWN
BATTERY CARRIAGE
D23582**

Assy No.	Part No.	Per Assy	Description
1	D23579	1	Assy - Carriage Frame (Includes 2-10)
2	C18258	1	Assy - Frame
3	B23519-1	1	Assy - Tongue
4	B23519-2	1	Assy - Tongue
5	K2833	4	Nut, Hex
6	K3036-12	4	Screw, Hex Hd. (Zink Plated)
7	K14180-8	4	Lockwasher
8	K14881-5	4	Lockwasher
9	K15741	4	Nut, Hex
10	K18397	4	Caster
11	D23581	1	Assy - Battery Case (Includes 12-36,38)
12	A18389	1	Assy - Jumper, Cable (Includes 17)
13	A18391	1	Assy - Cable (Includes 17, 18)
14	A18392	1	Assy - Cable (Includes 17, 19)
15	A18393	1	Assy - Cable (Includes 18, 19)
16	C23580	1	Assy - Case & Cover (Includes 20-28)
17	K18388	4	Lug, Battery
18	K18390	2	Terminal, Ring
19	K18383	2	Lug
20	B23574	1	Assy - Switch Bracket
21	C18255	1	Case
22	C18256	1	Cover
23	B18297	1	Hinge
24	A23578	1	Decal
25	K2871-6	8	Washer
26	B23723	1	Decal
27	K6001-24	4	Rivet
28	K22358	8	Pop Rivet
29	K2964-04	4	Lockwasher
30	K12465	1	Latch
31	K12563	4	Nut, Hex
32	K12580-8	4	Screw, Flat Hd.
33	K12713	2	Relief, Strain
34	K15984	2	Bushing
35	K18384	1	Housing, Plug
36	K23472	1	Circuit Breaker
37	K18275	2	Battery (Not Included)
38	K23813-5.5	1	Tubing, Insulating (Not Shown)

