

FIVE STAR™

OWNER'S MANUAL & PARTS LIST

This equipment is intended for commercial use only.

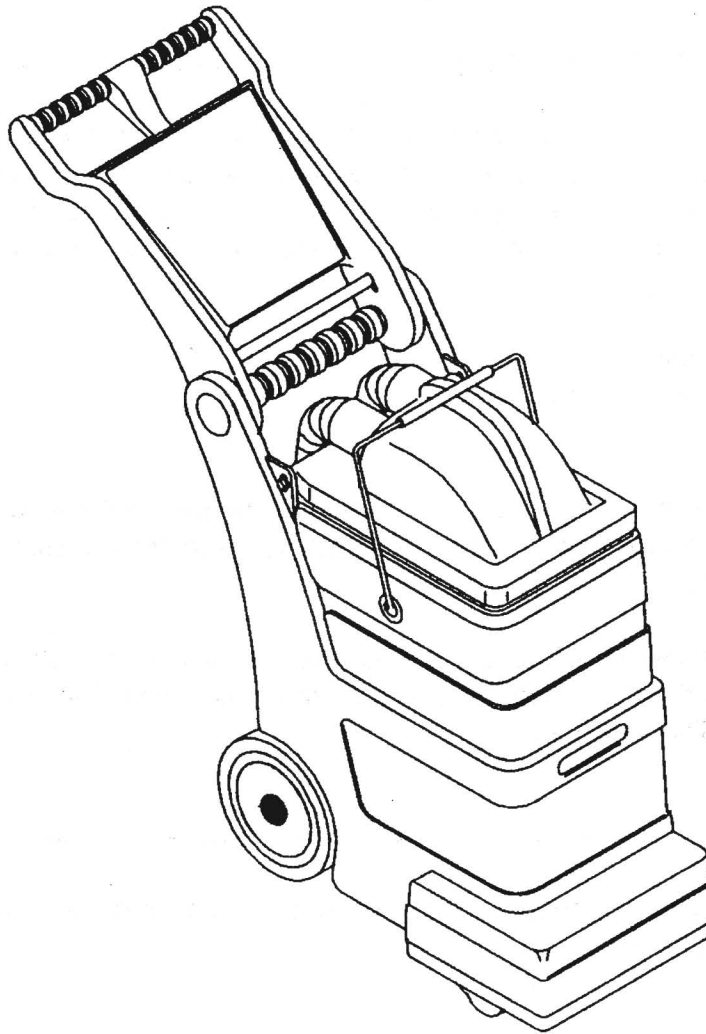

EDIC FIVE STAR™

400 SERIES EQUIPMENT



WHEN THE MACHINE IS DELIVERED

Check the carton carefully for signs of rough handling. Remove the machine from the carton. If the machine is damaged, notify the carrier immediately and request an inspection. Be sure to keep the carton, packing inserts, packing lists and carrier's receipt until the inspector has verified your claim.

EDIC's liability ceases when the shipment is picked up by the carrier but our customer service staff will be glad to furnish any information needed in connection with the claim and will expedite repair of the machine.

Obtain a return authorization number from the factory before returning the machine to us for repair or service.

BEFORE OPERATING THE MACHINE

Read the manual carefully and completely before attempting to operate the unit. This manual has important information for the use and safe operation of the machine. Keep this manual handy at all times. This machine will ensure years of satisfactory service if operated and maintained according to recommendations in the manual. If additional information is needed, please contact your local distributor or write to:

EDIC
1753 Blake Avenue
Los Angeles, California 90031-1006
(323) 660-1635

All information and specifications printed in the manual and parts list are current at the time of printing; however, because of EDIC's policy of continual product improvement, we reserve the right to make changes at any time without notice.

This machine is shipped with antifreeze in the solution line system to protect the pump and valves from freezing during transport and storage. Before you use the unit, rinse the solution line system with clean water (See Preparing The Machine).

WARRANTY

To protect your investment, promptly fill in the required information on the warranty card that comes with the unit and mail it back to EDIC.

WARNING

To reduce the risk of fire, electric shock, or injury:

- Do not leave the machine when plugged in. Unplug from the outlet when not in use and before servicing.
- Use indoors only.
- Do not allow to be used as a toy. Close attention is necessary when used by or near children.

WARNING

- The machine was designed for use on carpet, hard floors and upholstery extraction application as per instructions and recommendations written in this manual. Any deviation from its proper use or purpose and the consequential damage that may occur is the sole responsibility of the end user.
- Do not use with damaged cord or plug. If machine is not working as it should, or has been dropped, damaged, left outdoors, or dropped into water, return it to an authorized service center.
- Do not pull or carry by cord, use cord as a handle, close a door on cord, or pull cord around sharp edges or corners. Do not run machine over cord. Keep cord away from heated surfaces.
- Do not unplug by pulling on cord. To unplug, grasp the plug, not the cord.
- Do not handle plug or appliance with wet hands.
- Make sure the machine is plugged into an electrical outlet with the same voltage and frequency rating as shown on the nameplate of the machine. Do not attempt to plug a 115 volt machine into a 230 volt outlet.
- Do not immerse or use this machine in standing water. Such use can cause electric shock.
- Do not use to pick up flammable or combustible liquids such as gasoline or use in areas where they may be present.
- Do not expose machine to freezing temperatures.
- To avoid electric shock, do not expose the unit to rain — store it indoors only.
- Connect to a properly grounded outlet only. See “Grounding Instructions.”
- Turn off all controls before unplugging.
- Do not use without filters in place.
- Do not put any object into openings. Do not use with any opening blocked; keep free of dust, lint, hair and anything that may reduce air flow.
- Do not pick up anything that is burning or smoking, such as cigarettes, matches or hot ashes.
- Do not use machine for dry vacuuming. This machine is not outfitted with a fine dust filter and it will damage the vacuum motor(s).
- Do not turn on the vacuum-pump switch when the solution tank is empty.
- Use defoamer at all times to prevent damage to the vacuum motor.
- Do not use water in excess of 140 F (62 C).

WARNING

- Use only commercially available carpet cleaners and defoamer intended for use with extraction machines of this type. Do not use dyes, bleaches, ammonia, or other additives. The use of powdered cleaning solution if not diluted properly may result in damage to the pump.
- All servicing of EDIC equipment should be performed only by EDIC authorized service centers.
- Keep hair, loose clothing, fingers and all parts of body away from openings and moving parts.
- Use extra care when cleaning on stairs.
- Do not use replacement parts other than those specified in the parts list. Proper maintenance of the machine could be affected if substitutions are made.
- Follow maintenance schedule strictly.
- FAILURE TO COMPLY WITH THE WARNING INSTRUCTIONS WILL VOID THE WARRANTY.

GROUNDING INSTRUCTIONS

To protect the operator from electric shock, EDIC equipped the machine with an approved three conductor cord and grounding plug. This plug is to be used only with the proper grounding type receptacle.

The machine has a plug like the one shown in figure (A). An adapter is available for connecting three prong type plugs to two prong receptacles (see figure B). The green colored rigid lug extending from the adapter must be connected to a permanent ground such as a properly grounded outlet box. Do not break off or pull out the grounding prong on the plug because it protects the operator from electric shock.

CLEANING TIPS

- Check the condition of the area to be cleaned. Look for loose carpet, heavily soiled area, stains or spots and worn areas. Bring these to the attention of the person in charge before performing the cleaning job. Make sure all edges of the carpet are securely tacked in place and all seams are sewn (or glued) tight. This is your protection against shrinkage.
- Locate an inconspicuous spot on the area to be cleaned. Test carpet for colorfastness before proceeding. Pour the concentrated cleaning solution on the spot, cover with a white towel and place a heavy object on top to absorb the cleaning solution. Wait approximately 10 minutes for any reaction to take place. Remove weight. If there is no color transfer, it should be safe to clean. Apply this procedure if different color-texture carpet is seen in adjacent rooms or areas to be cleaned.
- Remove the furniture from the area to be cleaned. Large pieces can be moved to opposite end of the room from where you start cleaning and replaced when it is completed. After cleaning carpet, place a small square of aluminum foil under the furniture legs to prevent moisture from damaging the finish and

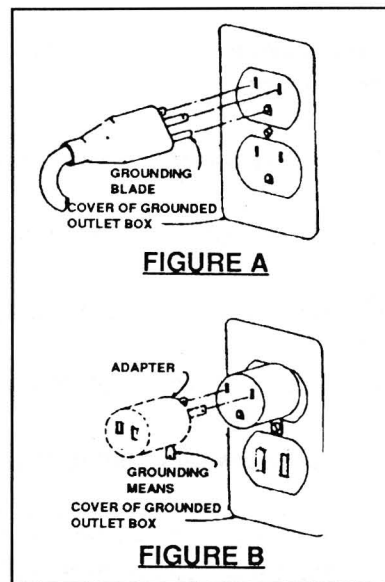

avoid dye and rust from transferring to the carpet.

- Clean the area with an upright vacuum. **DO NOT USE THIS MACHINE AS A DRY VACUUM!** Heavily soiled carpet or areas of concentrated foot traffic should be treated with recommended pre-spotting or pre-spray chemicals. If a spotter is used, follow label directions exactly. Do not allow any spotter or pre-spray to dry on the carpet as it may damage the carpet permanently.
- Identify the type of carpet fiber to be cleaned. Most commercial carpet fibers in use are acrylic or nylon based. Best results in cleaning would be obtained if hot water is used to clean these type of fibers. On the other hand, hot water would shrink natural fiber carpeting, like wool and cotton in particular. Exercise caution when cleaning natural fibers by using cool water, testing for colorfastness and applying the least amount of cleaning solution possible.
- Plan your cleaning route. Start cleaning at the farthest point away from where you plugged the machine and work back towards the outlet so that the cord will not get in the way.

TO CLEAN CARPET

1. Prepare the Machine

Make sure “switch” is in the “off” position and all hoses are connected. Using only approved cleaning solution, mix according to the bottle instructions using the “bucket.” To reduce foaming pour 2 ounces of defoamer into the recovery bladder. Place bucket onto machine and close lid.

2. To Clean

Turn switch to carpet position. If the machine is an all floor model turn the “solution control” valve located on the side of the machine to “carpet.” Turn pump switch “on.” While pushing “activate” switch pull machine as you step backwards. Release the “Activate” switch 6 inches before ending a stroke. Repeat cleaning stroke with 3” overlaps. Continue cleaning until cleaning solution is consumed. Empty and rinse bucket, repeat steps 1 and 2.

3. Check Bucket Lid

If excessive foam appears in lid add 2 ounces of defoamer or empty and rinse bucket, repeat steps 1 and 2.

4. Clean Machine Before Returning

Clean “Lid Filter Screens” and rinse out bucket. Wipe all surfaces including bottom of machine. Remove carpet lint and strings from brush and vacuum nozzle.

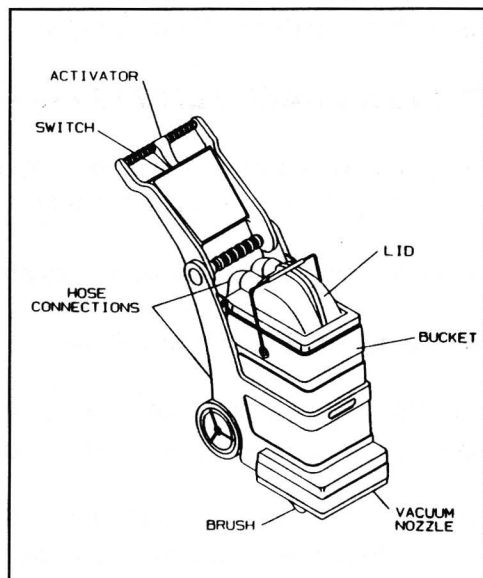

TO CLEAN UPHOLSTERY

Cleaning upholstery with success requires a good knowledge of the type of fabric to be worked on. Look for cleaning instruction label sewn on the underside of the furniture for the recommended method of cleaning the fabric. If it calls for dry cleaning, do not attempt to clean with the wet extraction method. Otherwise, damage to the fabric could occur. Extraction works on most synthetic fabrics.

Before proceeding, test fabric for colorfastness. Pour a small amount of cleaning solution on the fabric in an inconspicuous spot. Rub the area with a white terry towel. If no color comes off the towel, the fabric

an inconspicuous spot. Rub the area with a white terry towel. If no color comes off the towel, the fabric should be safe to clean. If color transfers, do not continue.

1. Prepare the Machine

Complete step 1 under Carpet Cleaning Instructions using approved Upholstery Cleaning Solution. Disconnect vacuum hose with black hose cuff from lid and disconnect solution hose from back of machine. Replace them with the upholstery hoses.

2. To Clean

Turn switch to upholstery position. If the machine is an all floor model turn the "solution control valve" located on the side of the machine to "carpet." Turn pump switch "on." Depress upholstery tool trigger while pulling tool across upholstery surface with overlapping strokes. To speed drying go over the upholstery without depressing trigger. Continue cleaning until cleaning solution is consumed. Empty and rinse bucket, repeat Step 1 and 2.

3. Check Bucket Lid

See Step 3 under "To Clean Carpet."

4. Clean Machine Before Returning

See step 4 under To Clean Carpet.

TO CLEAN HARD FLOORS ---

If your machine has a "solution control valve" located on the side of the machine, you may clean hard floors using the following instructions.

Turn the "solution control valve", located on the side of the machine to "floor."

WARNING: USE ONLY APPROVED FLOOR CLEANING SOLUTIONS.

WARNING: To avoid possible scratching on soft surfaces such as marble, vinyl, etc., remove all abrasive materials from the surface to be cleaned, such as sand, etc.

The Five Star™ is intended to be used to scrub and clean hard floor surfaces.

Do not use the machine to apply floor finish.

Do not use the machine to apply stripper.

Do not use the machine to vacuum up stripper.

When picking up harsher chemicals that have been applied to the floor using a separate sprayer, apply neutralizer through the machine to dilute the chemical that was applied to the floor.

1. Preparing the machine — See "To Clean Carpet" section 1.

2. To clean - Turn the "Solution Control Valve" located on the side of the machine to "floor" then follow sections 2, 3, and 4 under "To Clean Carpet."

DAILY MAINTENANCE ---

The Five Star™ is engineered and built to require minimum maintenance. But like any machine, it does require some care to keep it in optimum working condition. Careful attention to these maintenance instructions will give you maximum operating performance and life expectancy of the machine.

CAUTION: Disconnect power cord from the outlet before doing any clean up or maintenance on the machine.

1. Keep the machine clean, inside and out including the lid, bucket, brush and brush chamber.
2. Pour a gallon of clean hot water in the smaller opening of the bucket. Turn the pump on and flush the entire system through the spray nozzles for about a minute to prevent alkaline build-up.
3. Keep filters clean.
4. Quick connect coupler — spray with silicone lubricant to keep coupler from sticking.
5. Valve, upholstery tool — If the plunger on the valve sticks, spray with silicone lubricant.

TROUBLESHOOTING

ELECTRICAL SYSTEM

PROBLEM	POSSIBLE CAUSE
No electrical power.	<ol style="list-style-type: none"> 1. Defective power cord. 2. House or building circuit breaker tripped.
Switch is turned on. Power is intermittent to all motor(s)	<ol style="list-style-type: none"> 1. Faulty electrical cable. 2. Defective Switches 3. Loose terminal or terminal connections.
VACUUM SYSTEM	
No Vacuum	<ol style="list-style-type: none"> 1. Vacuum lid is not sealed against tank. 2. Loose vacuum hose, vacuum connection.
Low Vacuum	<ol style="list-style-type: none"> 1. Accumulated dirt on lid screen. 2. Worn out vacuum lid gasket. 3. Lint & dirt build-up on vacuum nozzle. 4. Defective vacuum hose. 5. Loose connection in the vacuum motor(s)
SOLUTION SYSTEM	
Pump motor is on, no spray through spray tip.	<ol style="list-style-type: none"> 1. Small opening side of bucket is empty. 2. Clogged spray tip. 3. Clogged filter screen on end of dome hose. 4. Plugged female quick disconnect coupler. 5. Punctured pump diaphragm. 6. Defective pump check valve. 7. Crack in pump housing. 8. Debris in check valve.
Uneven or weak spray from tip.	<ol style="list-style-type: none"> 1. Clogged or dirty spray tip. 2. Accumulated dirt on filter screen of dome hose. 3. Accumulation of debris inside pump and plumbing. 4. Worn pump bearing (excessive noise)/ 5. Punctured pump diaphragm. 6. Defective rectifier or motor. 7. Worn nozzles.
BRUSH SYSTEM	
Motor runs, brush won't spin.	<ol style="list-style-type: none"> 1. Defective belt. 2. Brush jammed.
Brush motor fails to turn on after circuit breaker has been reset.	<ol style="list-style-type: none"> 1. Brush jammed. 2. Blown breaker. 3. Defective motor. 4. Defective switch. 5. Loose wiring connection.

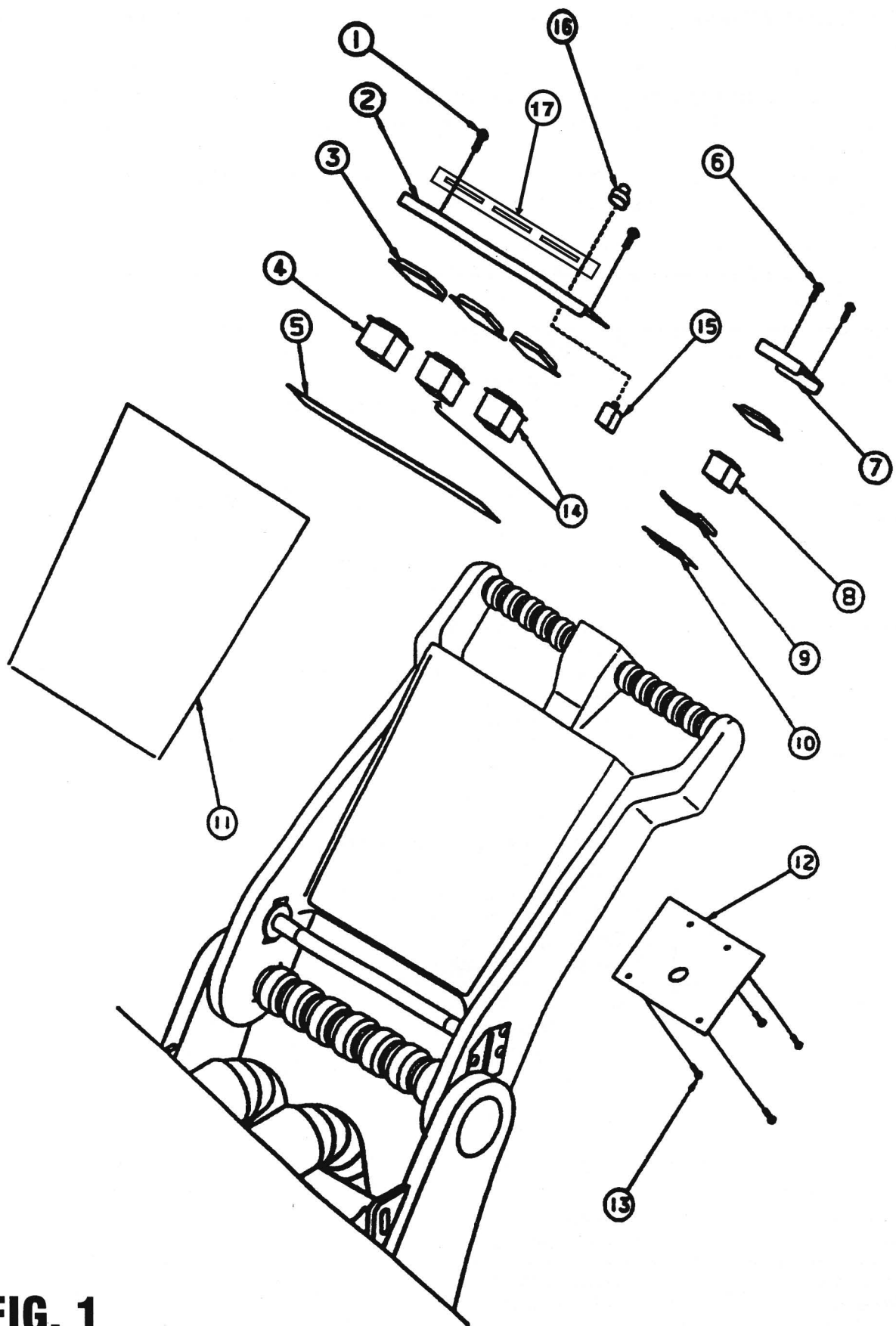

FIG. 1

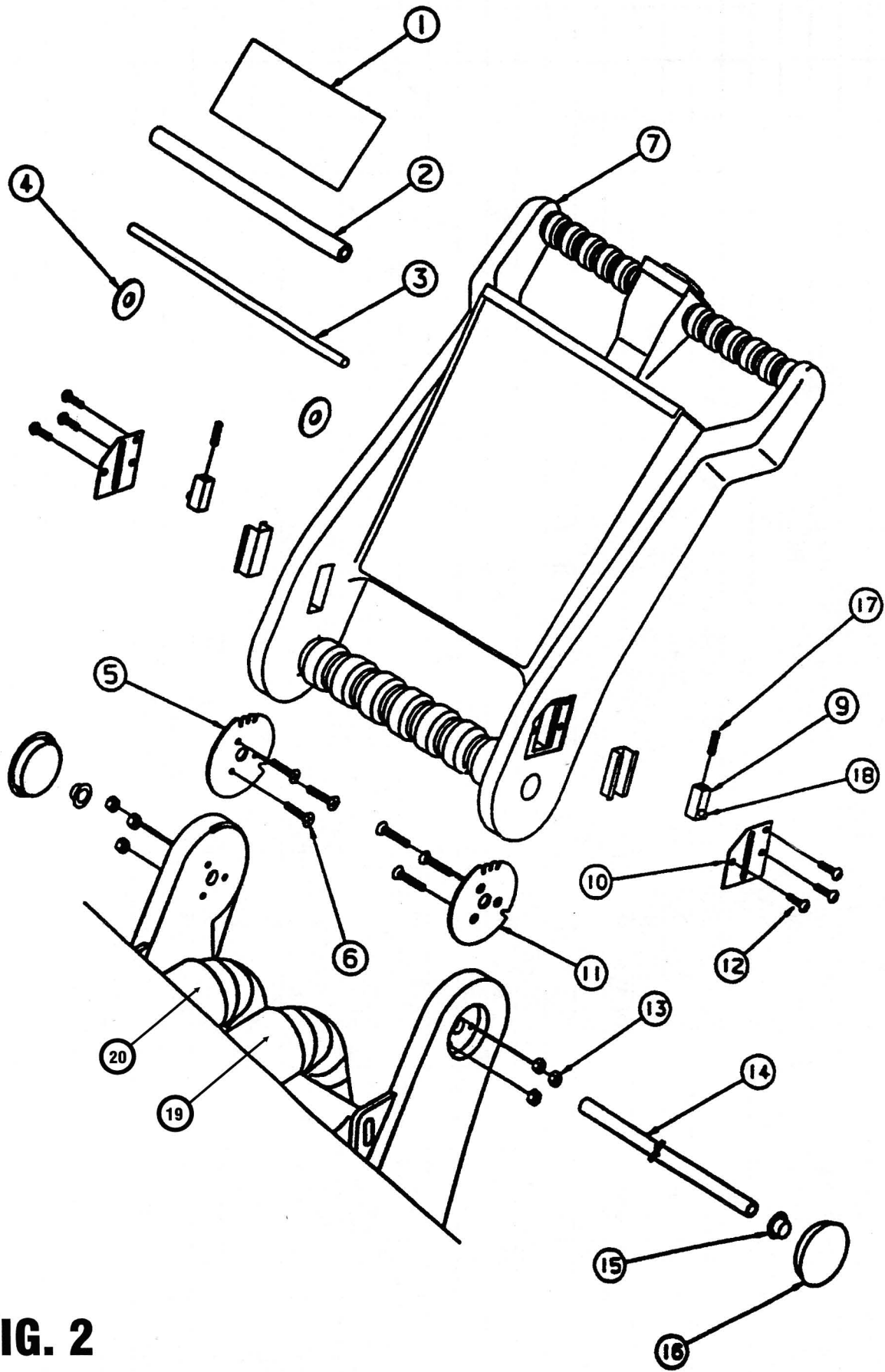

FIG. 2

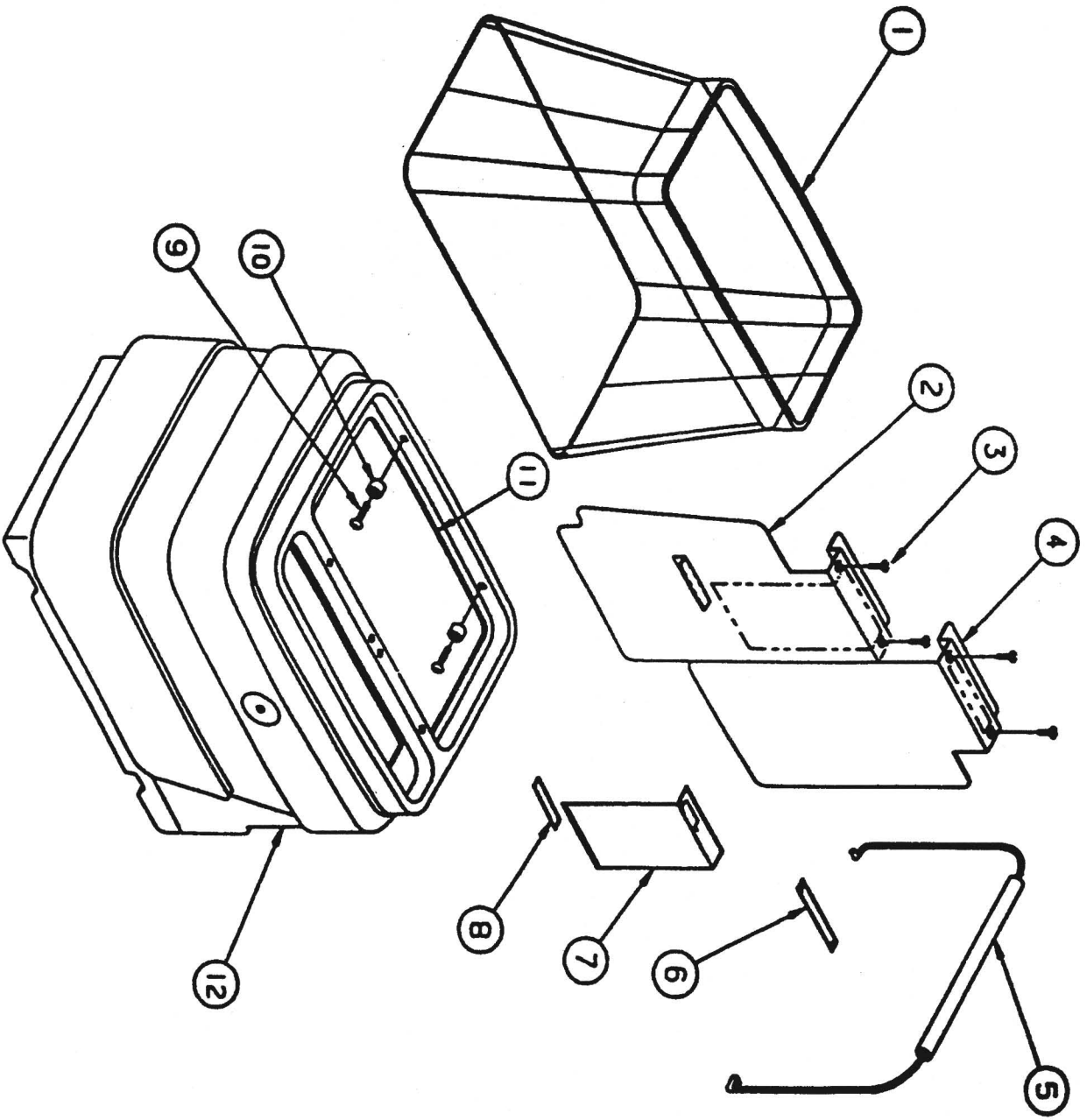

FIG. 3

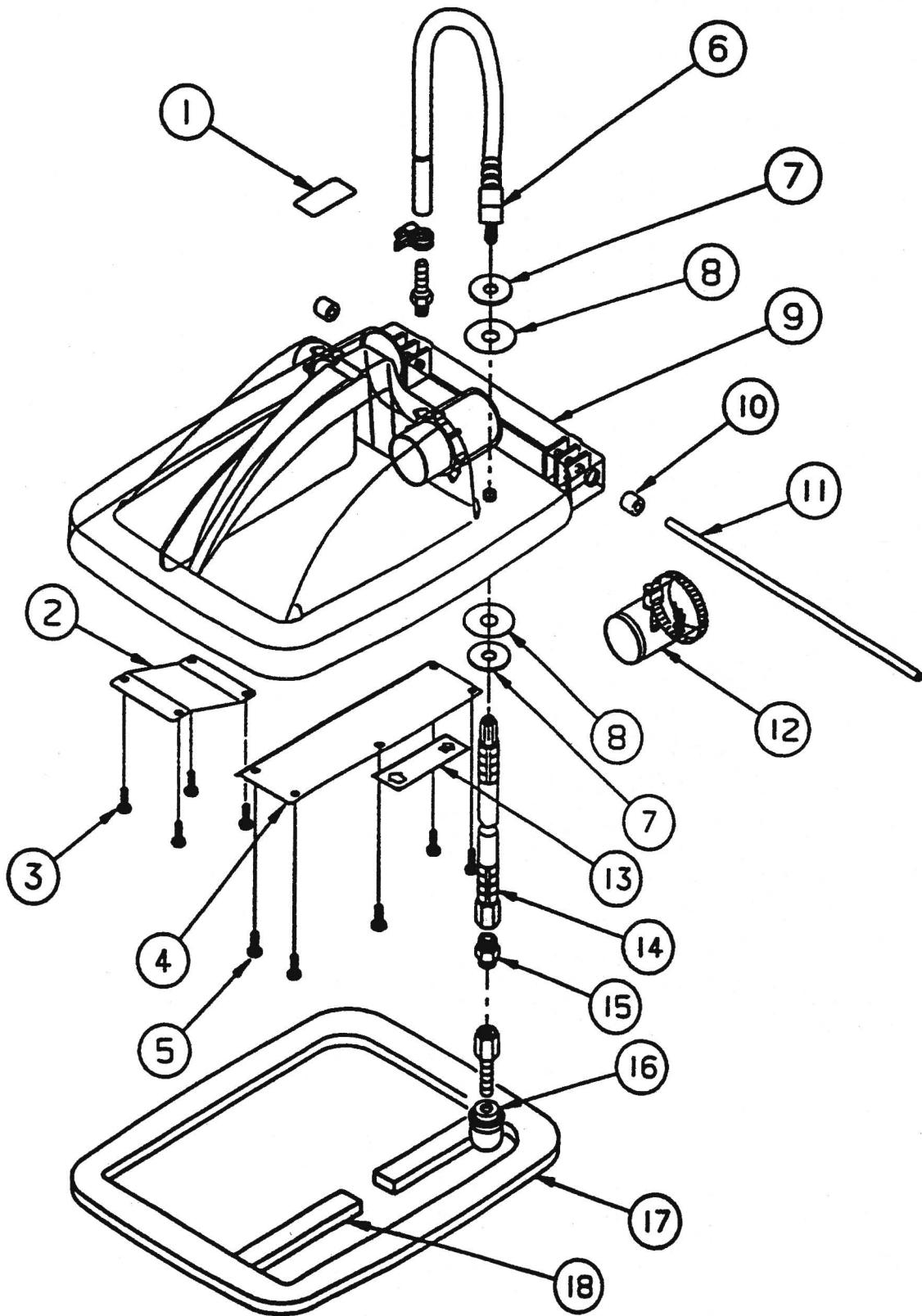

FIG. 4

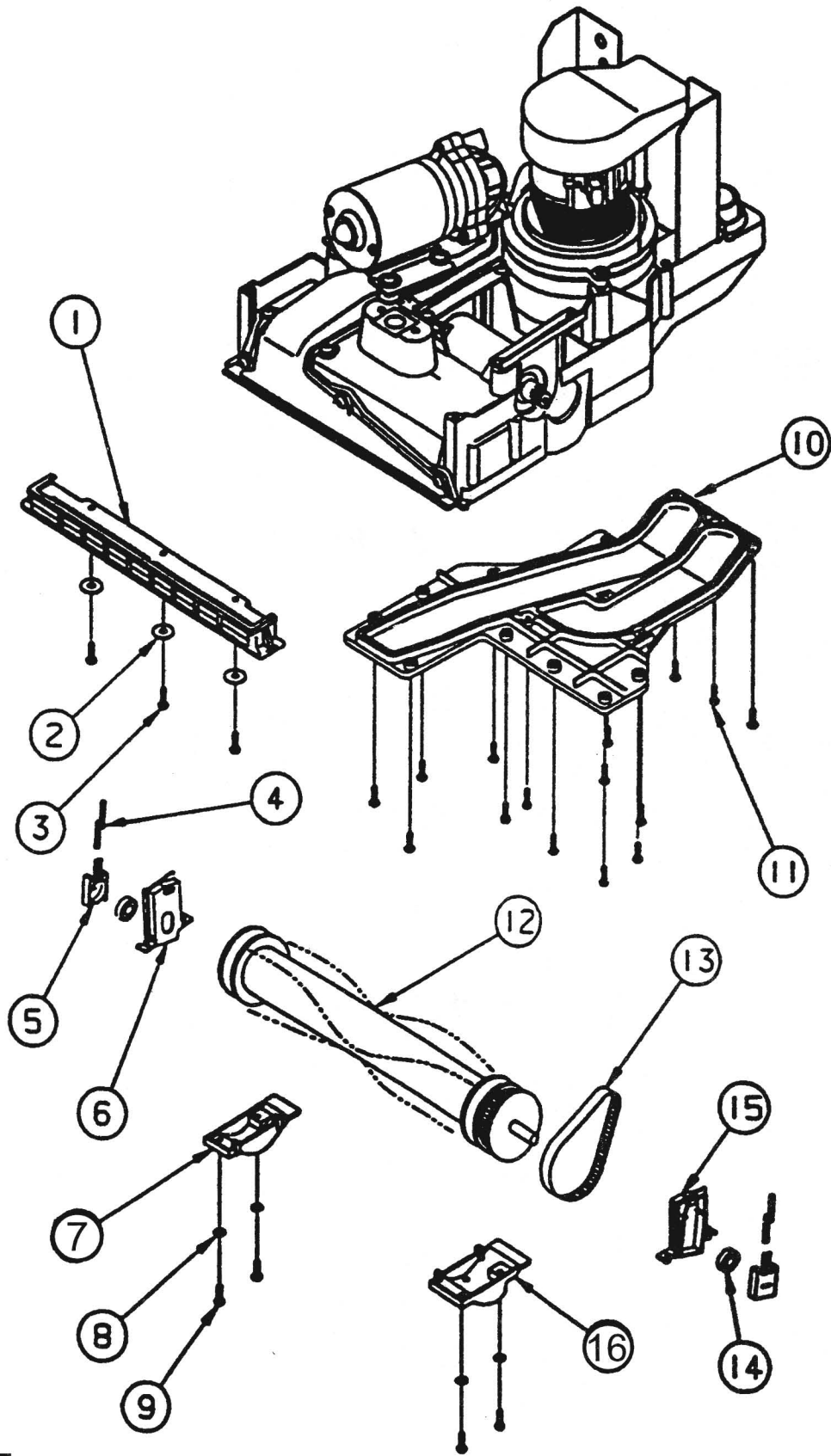

FIG. 5

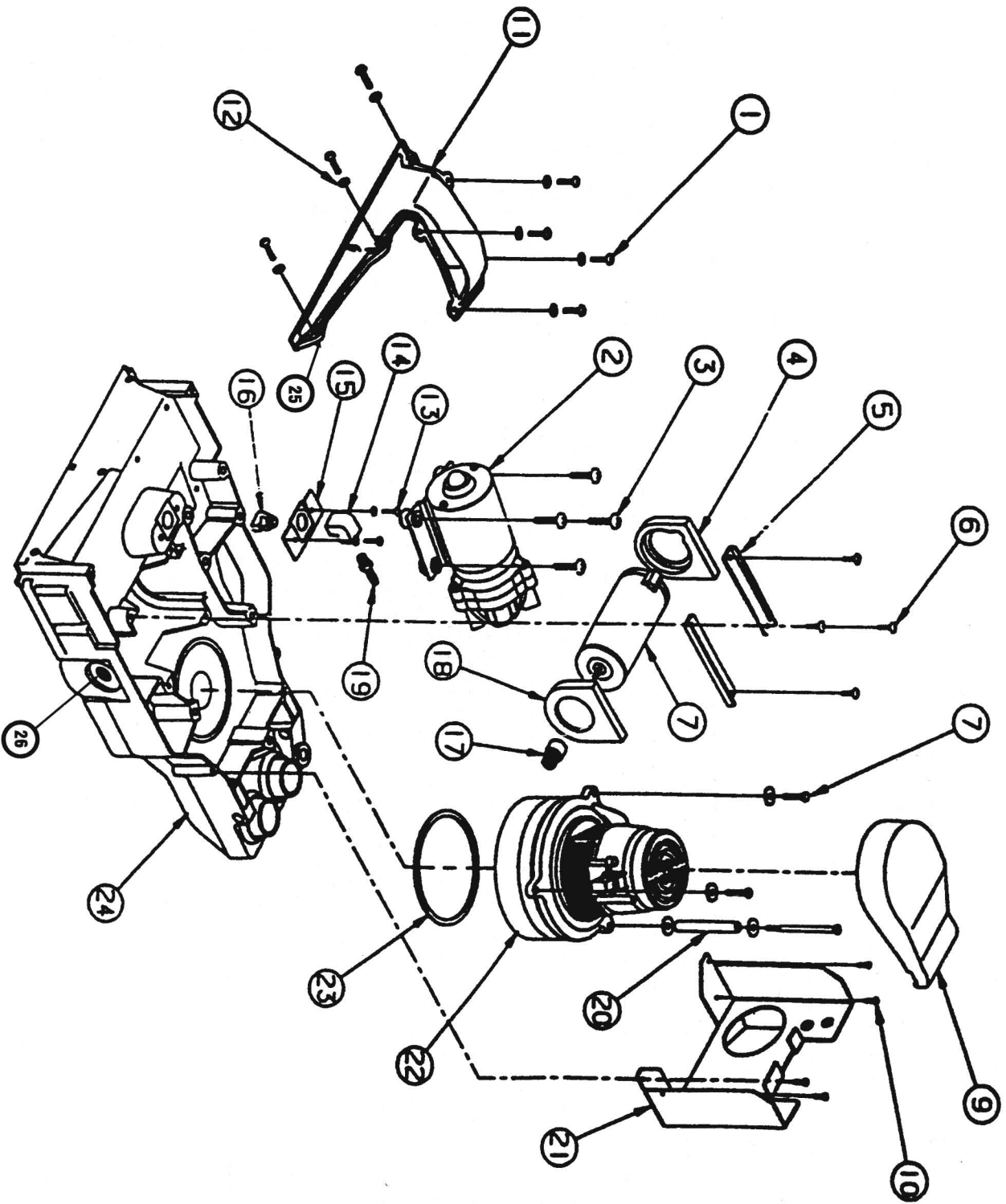

FIG. 6

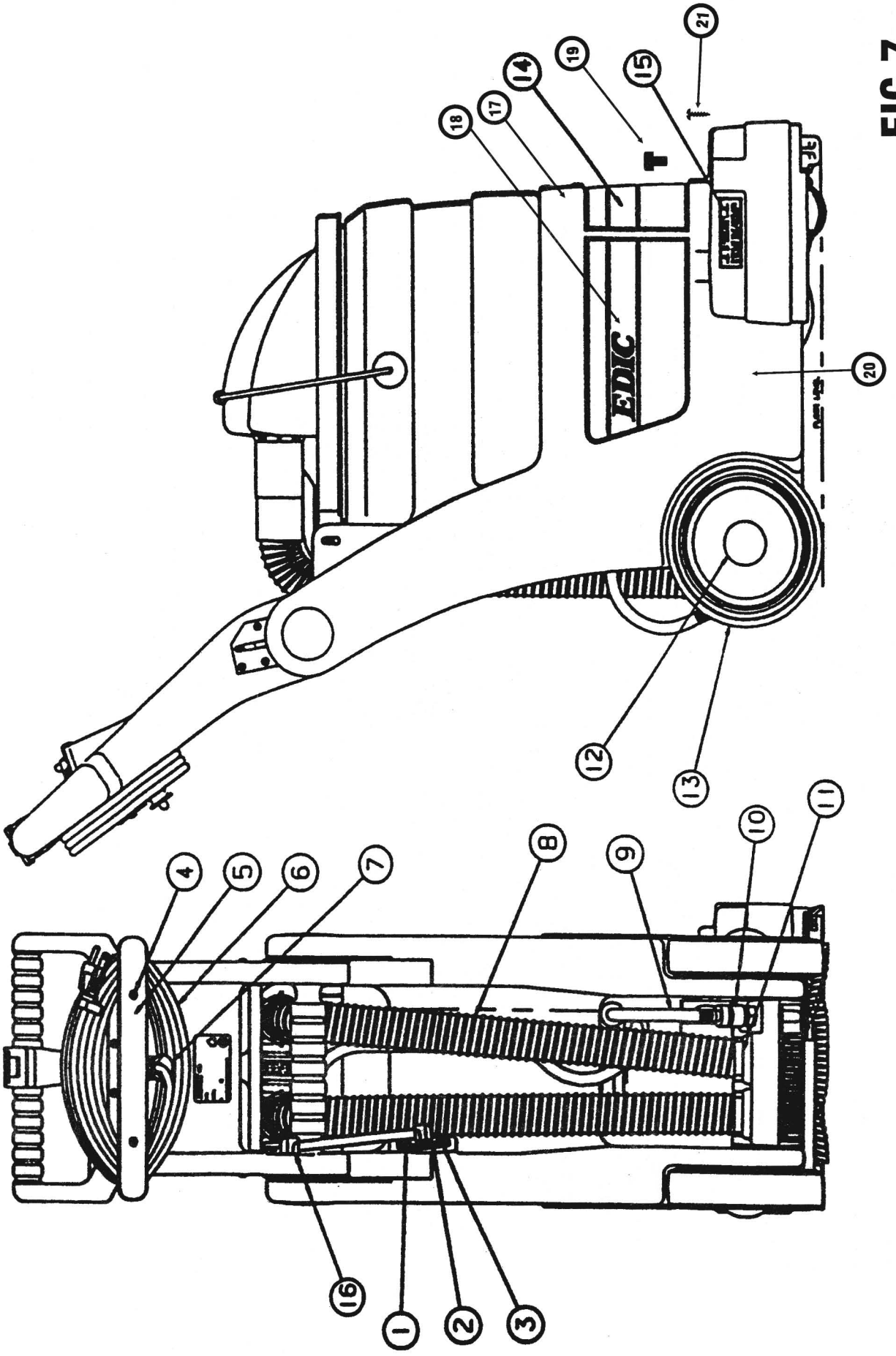

FIG. 7

EDIC PARTS LIST

ITEM #	PART #	DESCRIPTION	QTY.	FIG.
1	C90006	SCREW, 6-32 X 3/4, PHILLIPS PAN HEAD, BLACK OXIDE	4	7
2	D10618	PLATE, STRAIN RELIEF, BLACK	2	7
3	E10723	GASKET, STRAIN RELIEF	2	7
4	COO311	8-32 X 3/8 ROUNDEHEAD MACHINE, BLACK PHILLIPS SS	2	7
5	D10501	PLATE, CORD WRAP, BLACK	1	7
6	B10719	POWER CORD, 3/16 AWG, 300VAC, SJTO, 20', BLACK, W/NEMA 5-15 PLUG AND CORD CLIP	1	7
7	B02215	STRAIN RELIEF, BLACK TRUMPETED, 14-18 GA	1	7
8	J00618-1	1 1/2 WIRE SUPPORTED GRAY, WIRE REINFORCED	6	7
9	10531A	ASSY., HOSE, QUICK CNNECT	1	7
10	A00109	QUICK DISCONNECT 1/8 SOCKET X 1/8 FP BL	1	7
11	J00656	CLAMP, HOSE, 1 1/2" NYLON, REUSABLE, BLACK	2	7
12	G10458-2	CAP, WHEEL HUB, BLACK	2	7
13	G10458	WHEEL, 7 INCH, NO BEARING /375" BORE, GREY	2	7
14	H10727	LABEL, CENTER, WRAPAROUND, EDIC	1	7
14A	H10727-1	LABEL, CENTER, WRAPAROUND, (400TR)	1	7
15	H10577	LABEL, CAUTION, RISK OF ELECTRIC SHOCK, 1' X 2.875	1	7
16	B10734	STRAIN RELIEF, CORD, MAIN HARNESS	2	7
17	H10728	LABEL, MOTOR HOUSING, RIGHT, EDIC	1	7
17A	H10728	LABEL, MOTOR HOUSING, RIGHT, (400TR)	1	7
18	H10729	LABEL, MOTOR HOUSING, LEFT, EDIC	1	7
18A	H10729-1	LABEL, MOTOR HOUSING, LEFT, (400TR)	1	7
19	K10510	PLUG, HOLE 1"	2	7
20	F10541	MOTOR HOUSING (400TR)	1	7
20A	F10541-1	MOTOR HOUSING EDIC BLUE	1	7
20B	F10541-2	MOTOR HOUSING PURPLE	1	7
20C	F10541-3	MOTOR HOUSING BLACK	1	7
20D	F10541-4	MOTOR HOUSING K-BLUE	1	7
20E	F10541-5	MOTOR HOUSING K-GREY	1	7
21	C90007	SCREW, 10-32 X 5/8" PHILLIPS	2	7

NOTES

NOTES



ZF1204